

## Digital Indicator with Alarm function

# AE500

# Instruction Manual

IMAE01-E8

Thank you for purchasing this RKC product. In order to achieve maximum performance and ensure proper operation of your new instrument, carefully read all the instructions in this manual. Please place the manual in a convenient location for easy reference.



### WARNING

- To prevent injury to persons, damage to instrument and equipment, a suitable external protection device shall be required.
- All wiring must be completed before power is turned on to prevent electric shock, fire or damage to instrument and equipment.
- This instrument must be used in accordance with the specifications to prevent fire or damage to instrument and equipment.
- This instrument is not intended for use in locations subject to flammable or explosive gases.
- Do not touch high-voltage connections such as power supply terminals, etc. to avoid electric shock.
- RKC is not responsible if this instrument is repaired, modified or disassembled by other than factory-approved personnel. Malfunction can occur and warranty is void under these conditions.

### CAUTION

- This product is intended for use with industrial machines, test and measuring equipment. (It is not designed for use with medical equipment and nuclear energy.)
- This is a Class A instrument. In a domestic environment, this instrument may cause radio interference, in which case the user may be required to take additional measures.
- This instrument is protected from electric shock by reinforced insulation. Provide reinforced insulation between the wire for the input signal and the wires for instrument power supply, source of power and loads.
- Be sure to provide an appropriate surge control circuit respectively for the following:
  - If input/output or signal lines within the building are longer than 30 meters.
  - If input/output or signal lines leave the building, regardless the length.
- This instrument is designed for installation in an enclosed instrumentation panel. All high-voltage connections such as power supply terminals must be enclosed in the instrumentation panel to avoid electric shock by operating personnel.
- All precautions described in this manual should be taken to avoid damage to the instrument or equipment.
- All wiring must be in accordance with local codes and regulations.
- All wiring must be completed before power is turned on to prevent electric shock, instrument failure, or incorrect action. The power must be turned off before repairing work for input break and output failure including replacement of sensor, contactor or SSR, and all wiring must be completed before power is turned on again.
- To prevent instrument damage as a result of failure, protect the power line and the input/output lines from high currents with a suitable overcurrent protection device with adequate breaking capacity such as fuse, circuit breaker, etc.

- Prevent metal fragments or lead wire scraps from falling inside instrument case to avoid electric shock, fire or malfunction.
- Tighten each terminal screw to the specified torque found in the manual to avoid electric shock, fire or malfunction.
- For proper operation of this instrument, provide adequate ventilation for heat dispensation.
- Do not connect wires to unused terminals as this will interfere with proper operation of the instrument.
- Turn off the power supply before cleaning the instrument.
- Do not use a volatile solvent such as paint thinner to clean the instrument. Deformation or discoloration will occur. Use a soft, dry cloth to remove stains from the instrument.
- To avoid damage to instrument display, do not rub with an abrasive material or push front panel with a hard object.

### NOTICE

- This manual assumes that the reader has a fundamental knowledge of the principles of electricity, process control, computer technology and communications.
- The figures, diagrams and numeric values used in this manual are only for purpose of illustration.
- RKC is not responsible for any damage or injury that is caused as a result of using this instrument, instrument failure or indirect damage.
- RKC is not responsible for any damage and/or injury resulting from the use of instruments made by imitating this instrument.
- Periodic maintenance is required for safe and proper operation of this instrument. Some components have a limited service life, or characteristics that change over time.
- Every effort has been made to ensure accuracy of all information contained herein. RKC makes no warranty expressed or implied, with respect to the accuracy of the information. The information in this manual is subject to change without prior notice.
- No portion of this document may be reprinted, modified, copied, transmitted, digitized, stored, processed or retrieved through any mechanical, electronic, optical or other means without prior written approval from RKC.

## 1. PRODUCT CHECK

Before using the product, check each of the following. If any of the products are missing, damaged, or if your manual is incomplete, please contact RKC sales office or the agent.

- Model code
- Check that all of the items delivered are complete.
- Check that there are no scratch or breakage in external appearance (case, front panel, or terminal, etc).

AE500 □□□-□ \*□□□□ - □□/ □ /Y  
(1) (2) (3) (4)(5)(6)(7) (8)(9)(10)(11)

(1) **Input type:** Refer to 9. **INPUT RANGE TABLE.**

(2) **Range code:** Refer to 9. **INPUT RANGE TABLE.**

(3) **Power supply voltage**

3: 24 V AC/DC

4: 100 to 240 V AC

(4) **Alarm 1 [ALM1], (5) Alarm 2 [ALM2]**

N: No alarm

K: Process high alarm with hold action

H: Process high alarm

L: Process low alarm with hold action

J: Process low alarm

(6) **Alarm 3 [ALM3] or Analog output**

N: No function

K: Process high alarm with hold action

H: Process high alarm

L: Process low alarm with hold action

J: Process low alarm

7: Analog output (0 to 20 mA DC)

8: Analog output (4 to 20 mA DC)

(7) **Alarm 4 [ALM4] or Power supply for LED drive**

N: No alarm

K: Process high alarm with hold action

H: Process high alarm

L: Process low alarm with hold action

J: Process low alarm

P: LED drive power supply for SP400/SP500 \*

\* This power supply is used to light the LED of the SP400/SP500.

### (8) Communication function

N: No communication function  
5: RS-485 (2-wire system)

### (9) Waterproof/Dustproof construction

N: No waterproof/Dustproof construction  
1: Waterproof/Dustproof construction

### (10) Case color

N: White  
A: Black

### (11) Version symbol

No code: For Japanese domestic market  
/Y: For International market

#### <Accessories>

Mounting brackets (KCA400-532): 2  
Instruction manual (IMAE01-E8): 1

## 2. MOUNTING



### WARNING

To prevent electric shock or instrument failure, always turn off the power before mounting or removing the instrument.

### 2.1 Mounting Cautions

- This instrument is intended to be used under the following environmental conditions. **(IEC61010-1)**  
[OVERVOLTAGE CATEGORY II, POLLUTION DEGREE 2]
- Use this instrument within the following environment conditions:
  - Allowable ambient temperature: 0 to 50 °C
  - Allowable ambient humidity: 5 to 95 %RH  
(Absolute humidity: MAX. W. C 29.3 g/m<sup>3</sup> dry air at 101.3 kPa)
  - Installation environment conditions: Indoor use,  
Altitude up to 2000 m
- Avoid the following conditions when selecting the mounting location:
  - Rapid changes in ambient temperature which may cause condensation.
  - Corrosive or inflammable gases.
  - Direct vibration or shock to the mainframe.
  - Water, oil, chemicals, vapor or steam splashes.
  - Excessive dust, salt or iron particles.
  - Excessive induction noise, static electricity, magnetic fields or noise.
  - Direct air flow from an air conditioner.
  - Exposure to direct sunlight.
  - Excessive heat accumulation.
- Mount this instrument in the panel considering the following conditions:
  - Provide adequate ventilation space so that heat does not build up.
  - Do not mount this instrument directly above equipment that generates large amount of heat (heaters, transformers, semi-conductor functional devices, large-wattage resistors.)
  - If the ambient temperature rises above 50 °C, cool this instrument with a forced air fan, cooler, etc. Cooled air should not blow directly on this instrument.
  - In order to improve safety and the immunity to withstand noise, mount this instrument as far away as possible from high voltage equipment, power lines, and rotating machinery.  
High voltage equipment: Do not mount within the same panel.  
Power lines: Separate at least 200 mm.  
Rotating machinery: Separate as far as possible.
  - For correct functioning mount this instrument in a horizontal position.
- In case this instrument is connected to a supply by means of a permanent connection, a switch or circuit-breaker shall be included in the installation. This shall be in close proximity to the equipment and within easy reach of the operator. It shall be marked as the disconnecting device for the equipment.

## 2.2 Dimensions

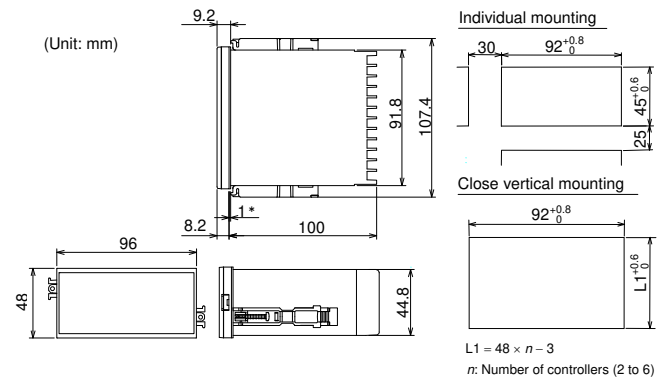

\*Rubber (Optional)

- For mounting of the instrument, panel thickness must be between 1 to 10 mm. (When mounting multiple instruments close together, the panel strength should be checked to ensure proper support.)
- Waterproof and Dustproof are not effective when instruments are closely spaced.

## 2.3 Mounting Procedures

### <Mounting Procedures>

- Prepare the panel cutout as specified in **2.2 Dimensions**.
  - Insert the instrument through the panel cutout.
  - Insert the mounting bracket into the mounting groove of the instrument. Do not push the mounting bracket forward. (Fig. 1)
  - Secure the bracket to the instrument by tightening the screw. Take care to refrain from moving the bracket forward.
  - Only turn about one full revolution after the screw touches the panel. (Fig. 2)
- If the screw has been rotated too tight, the screw may turn idle. In such a case, loosen the screw once and tighten it again until the instrument is firmly fixed.
- The other mounting bracket should be installed in the same way as described in **3. to 5.**

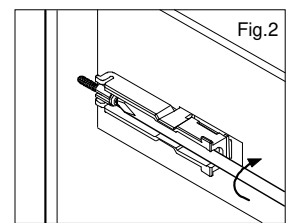
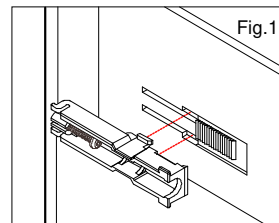

- The optional waterproof/dustproof on the front of the instrument conforms to IP65 when mounted on the panel. For effective waterproof/dustproof, the gasket must be securely placed between instrument and panel without any gap. If gasket is damaged, please contact RKC sales office or the agent.

### <Removal Procedures>

- Turn the power OFF.
- Remove the wiring.
- Loosen the screw of the mounting bracket.
- Hold the mounting bracket by the edge (①) and tilt it (②) to remove from the case. (Fig. 3)
- The other mounting bracket should be removed in the same way as described in **3. and 4.**
- Pull out the instrument from the mounting cutout while holding the front panel frame of this instrument. (Fig. 4)

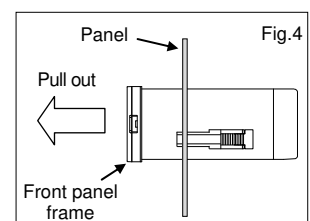
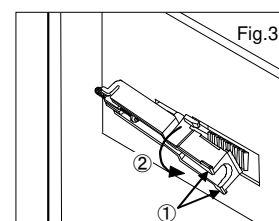

## 3. WIRING



### WARNING

To prevent electric shock or instrument failure, do not turn on the power until all wiring is completed. Make sure that the wiring is correct before applying power to the instrument.

### 3.1 Wiring Cautions

- For thermocouple input, use the appropriate compensation wire.
- For RTD input, use low resistance lead wire with no difference in resistance between the three lead wires.
- To avoid noise induction, keep input signal wire away from instrument power line, load lines and power lines of other electric equipment.
- For the current input specification, an external resistor (250  $\Omega$   $\pm$ 0.02 %, 0.25 W or more,  $\pm$ 10 ppm/ $^{\circ}$ C) must be connected between the input terminals. For external resistor (shunt resistor), use the KD100-55: sold separately (RKC product). If this resistor is installed, close horizontal mounting is not possible.
- Signal connected to Voltage input and Current input shall be low voltage defined as “SELV” circuit per IEC 60950-1.
- If there is electrical noise in the vicinity of the instrument that could affect operation, use a noise filter.
  - Shorten the distance between the twisted power supply wire pitches to achieve the most effective noise reduction.
  - Always install the noise filter on a grounded panel. Minimize the wiring distance between the noise filter output and the instrument power supply terminals to achieve the most effective noise reduction.
  - Do not connect fuses or switches to the noise filter output wiring as this will reduce the effectiveness of the noise filter.
- Allow approximately 5 to 6 seconds for contact output when the instrument is turned on. Use a delay relay when the output line is used for an external interlock circuit.
- Power supply wiring must be twisted and have a low voltage drop.
- This instrument with 24 V power supply is not provided with an overcurrent protection device. For safety install an overcurrent protection device (such as fuse) with adequate breaking capacity close to the instrument.
  - Fuse type: Time-lag fuse (Approved fuse according IEC60127-2 and/or UL248-14)
  - Fuse rating: Rated current: 0.5 A
- For an instrument with 24 V power supply input, supply power from “SELV” circuit defined as IEC 60950-1.
- A suitable power supply should be considered in end-use equipment. The power supply must be in compliance with a limited-energy circuits (maximum available current of 8 A).
- Use the solderless terminal appropriate to the screw size.
  - Screw size: M3 x 6
  - Recommended tightening torque: 0.4 N·m [4 kgf·cm]
  - Specified solderless terminals: With isolation
  - Applicable wire: Solid/twisted wire of 0.25 to 1.65 mm<sup>2</sup>
- Make sure that during field wiring parts of conductors cannot come into contact with adjacent conductive parts.

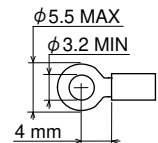
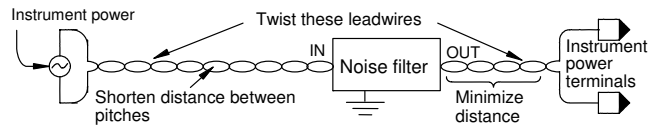

### 3.2 Terminal Configuration

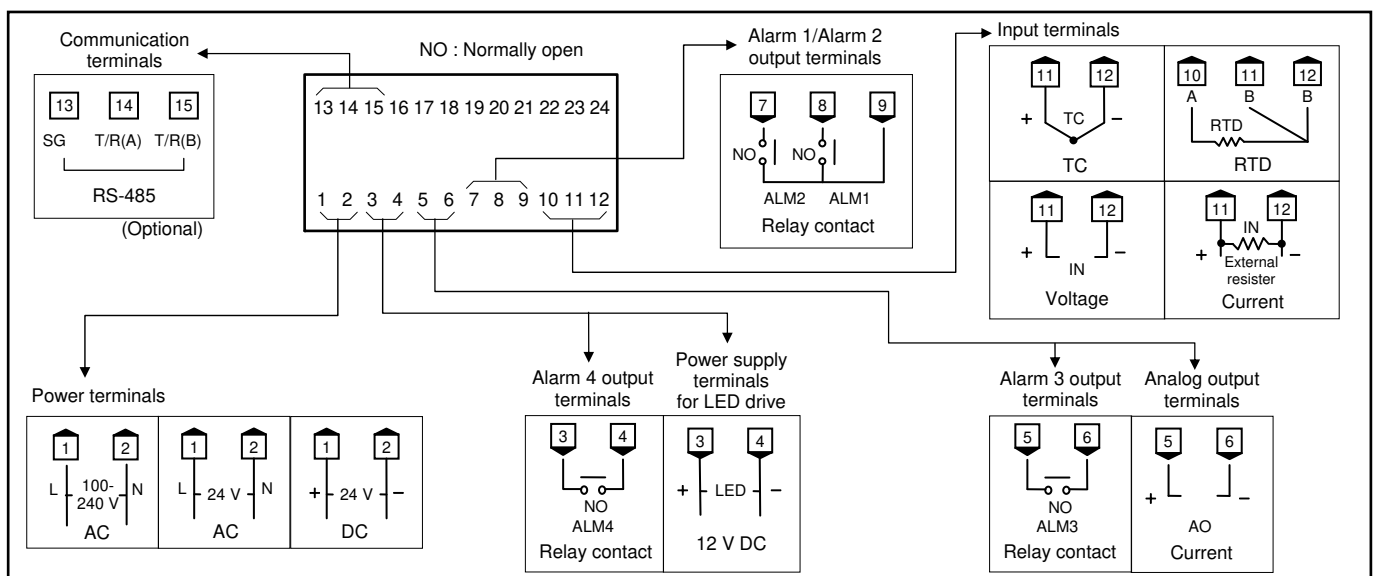

## ■ Specifications

### Power consumption

7 VA max. (at 100 V AC)  
 10 VA max. (at 240 V AC)  
 5 VA max. (at 24 V AC)  
 160 mA max. (at 24 V DC)

### Analog output (Optional)<sup>1</sup>

Number of output points: 1 point  
 Output resolution: 10 bits or more  
 Output rating: 0 to 20 mA DC  
 Load resistor: Less than 600 Ω

### Power supply for LED drive (Optional)<sup>2</sup>

Output voltage: 12 V DC<sup>+1 V</sup><sub>-2 V</sub>  
 Number of connection of SP400/SP500:  
 Max. 2 with the TF and 1 without TF.  
 (TF: Transfer switch type)

<sup>1</sup> When this option is specified, alarm 3 output is not available.  
<sup>2</sup> When this option is specified, alarm 4 output is not available.

### Power supply voltage

85 to 264 V AC (Power supply voltage range) 50/60 Hz Rating: 100 to 240 V AC  
 21.6 to 26.4 V AC (Power supply voltage range) 50/60 Hz Rating: 24 V AC  
 21.6 to 26.4 V DC (Power supply voltage range) Rating: 24 V DC

### Weight

Approx. 250 g

### Alarm output (Optional)

Alarm 1/Alarm 2: Relay contact output 250 V AC, 1 A (Resistive load), 1a contact  
 Alarm 3/Alarm 4: Relay contact output 250 V AC, 3 A (Resistive load), 1a contact

## 3.3 Wiring Example

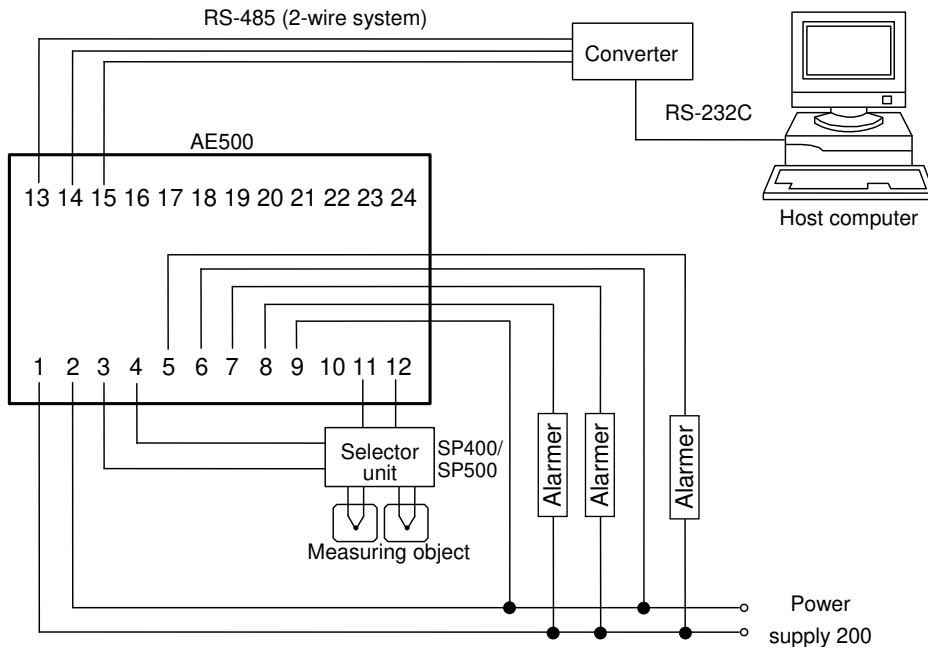

## 4. PARTS DESCRIPTION

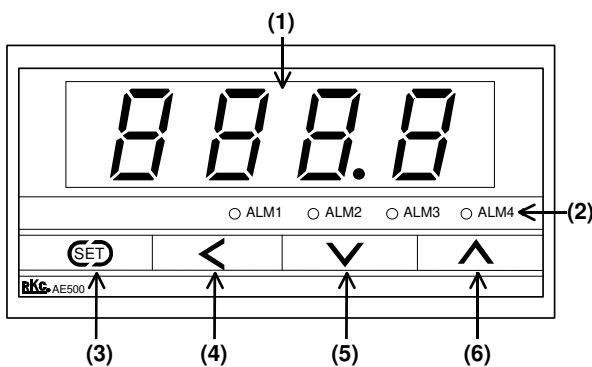

### (1) Measured value (PV) display unit

Displays measured value (PV).  
 Displays various characters depending on the instrument.

### (2) Alarm output indication lamps (ALM1 to ALM4) [Red]

ALM1: Lights when alarm 1 output is turned on.  
 ALM2: Lights when alarm 2 output is turned on.  
 ALM3: Lights when alarm 3 output is turned on.  
 ALM4: Lights when alarm 4 output is turned on.

### (3) (SET) (Set key)

Used for parameter calling up and set value registration.

### (4) < (Shift key)

Shift digits when settings are changed.  
 Used when the character display in each mode is changed to the set value display.

### (5) ∨ (Down key)

Decrease numerals.

### (6) ^ (Up key)

Increase numerals.



To avoid damage to the instrument, never use a sharp object to press keys.

## 5. SETTING

### 5.1 Calling-up Procedure of Each Mode

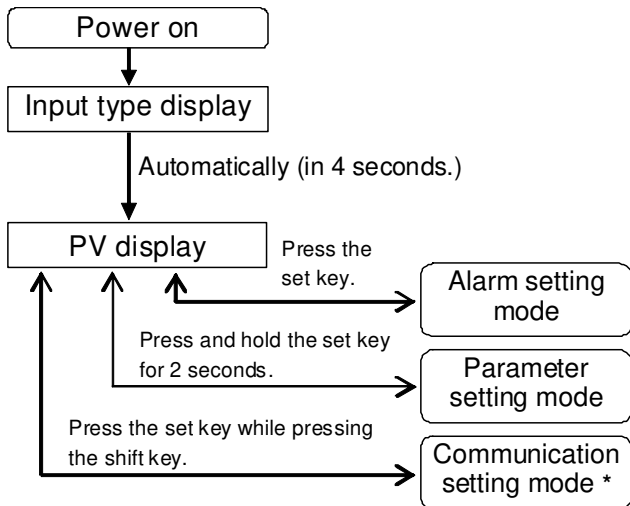

Displays returns to the PV display mode if no key operation is performed within 1 minute.

\* Displayed when the instrument has the communication function.

For details the protocol, identifiers and communication setting mode, refer to the separate **AE500 Communication Instruction Manual (IMAE02-E□)**.

### ■ Input type display

This instrument immediately confirms the input type symbol and engineering unit symbol following power on.

[Example] For an instrument with the K thermocouple input type and range from 0 to 1372 °C.

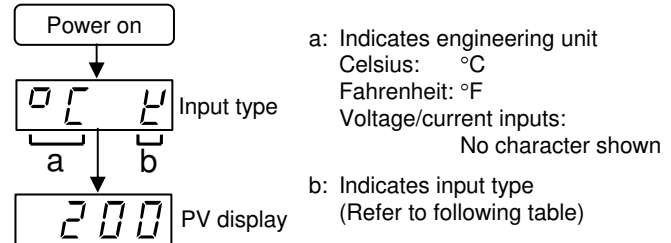

Display	E	J	R	S	B	E	T	N	PLII	W5Re/W26Re
Input type	TC									

Display	U	L	JP	Pt	H
Input type	TC		RTD		Voltage (Current)
	U	L	JPt100	Pt100	

### 5.2 Details of Each Mode

#### ■ Alarm setting mode

This is the mode used to set the alarm (alarm 1 to alarm 4). The following parameter symbols are displayed one by one every time the set key is pressed.

For details, refer to the **5.3 Parameter Setting Procedure (P. 7)**.

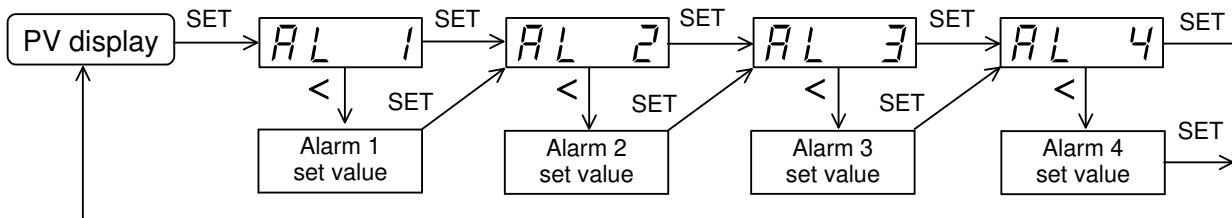

SET : Press the set key.

< : Press the shift key.

Symbol	Name	Setting (display) range	Description	Factory set value
AL 1	Alarm 1 setting	TC/RTD inputs: -1999 to +9999 °C [°F] or -199.9 to +999.9 °C [°F]	Set the alarm 1 set value.	TC/RTD inputs: 0 or 0.0 Voltage/Current inputs: 0.0
AL1			Set the alarm 2 set value.	
AL 2	Alarm 2 setting	Voltage/Current inputs: -1999 to +9999	Set the alarm 3 set value. Not displayed when there is analog output.	
AL2			Set the alarm 4 set value. Not displayed when there is power supply for LED drive.	
AL 3	Alarm 3 setting			
AL3				
AL 4	Alarm 4 setting			
AL4				

## Parameter setting mode

This is the mode used to set the various parameters such as alarm differential gap, PV bias etc. The following parameter symbols are displayed one by one every time the set key is pressed. (Press and hold the set key for 2 seconds when enter parameter setting mode from PV display.)

 For details, refer to the **5.3 Parameter Setting Procedure (P. 7)**.

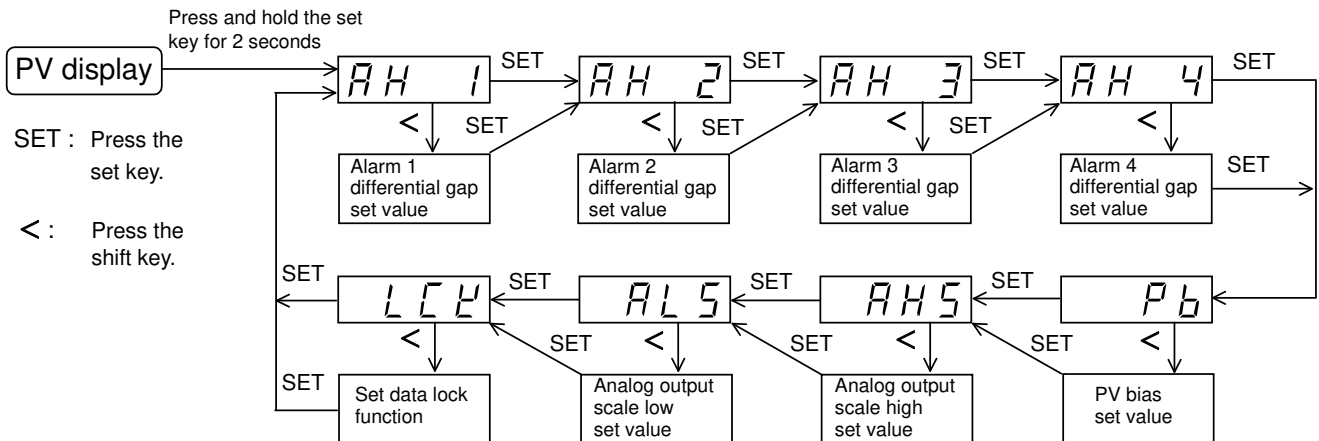

Symbol	Name	Setting (display) range	Description	Factory set value
AH 1	Alarm 1 differential gap setting	TC/RTD inputs: 0 to 100 °C [°F] or 0.0 to 100.0 °C [°F]	Set the alarm 1 differential gap.	TC/RTD inputs: 2 or 2.0 Voltage/Current inputs: 0.2
AH1				
AH 2	Alarm 2 differential gap setting	Voltage/Current inputs: 0.0 to 10.0 %	Set the alarm 2 differential gap.	
AH2				
AH 3	Alarm 3 differential gap setting		Set the alarm 3 differential gap. Not displayed when there is analog output	
AH3				
AH 4	Alarm 4 differential gap setting.		Set the alarm 4 differential gap. Not displayed when there is power supply for LED drive.	
AH4				
Pb	PV bias	TC/RTD inputs: -1999 to +9999 °C [°F] or -199.9 to +999.9 °C [°F] Voltage/Current inputs: -Input span to +Input span However, within -1999 to +9999	Sensor correction is made by adding bias value to measured value (PV).	TC/RTD inputs: 0 or 0.0 Voltage/Current inputs: 0.0
Pb				
AHS	Analog output scale high	ALS to SLH (Setting limiter high)	Sets high limit of the analog output range. Not displayed when there is no analog output.	SLH
AHS				
ALS	Analog output scale low	SLL (Setting limiter low) to AHS	Sets low limit of the analog output range. Not displayed when there is no analog output.	SLL
ALS				
LCK	Set data lock function	0000: Can be changed 0001: Cannot be changed	Selects the set data can be changed or cannot be changed.	0000
LCK				

### 5.3 Parameter Setting Procedure



When the displayed value is changed, it is not stored. To store it, press the set key.



After a new value has been displayed by using the up and down keys, the set key must be pressed within 1 minute, or the new value is not stored and the display will return to the PV display.

#### Change the Alarm set value

Example: Change the Alarm 1 set value from 0 °C to 200 °C.

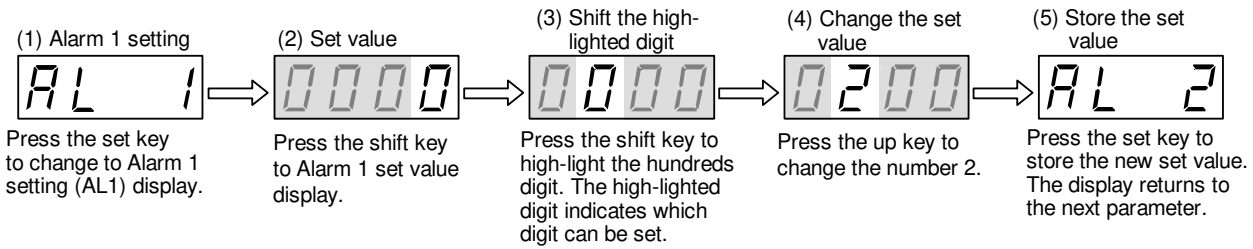

## 6. OPERATIONS

### CAUTIONS

- All mounting and wiring must be completed before the power is turned on. If the input signal wiring is disconnected or short-circuited (RTD input only), the instrument determines that burnout has occurred.
  - Displays:
    - Upscale: Thermocouple input, RTD input (when input break)
    - Downscale: Thermocouple input (specify when ordering), RTD input (when short-circuited), Voltage input (1 to 5 V DC), Current input (4 to 20 mA DC)
  - For the voltage (0 to 5 V DC, 0 to 10 V DC\*) or current (0 to 20 mA DC) input, the display becomes indefinite (display of about zero value).
    - \* Z-1010 specification
- Alarm action:
 

The Alarm 1, Alarm 2, Alarm 3 and Alarm 4 actions of this instrument are turned on when burnout occurs regardless of any of the following actions taken (High alarm, low alarm, etc.). In addition, when used for any purposes other than these alarms (event, etc.), specify the Z-124 specification (not to be forcibly turned on).
- A power failure of 20 ms or less will not affect the control action. When a power failure of more than 20 ms occurs, the instrument assumes that the power has been turned off. When power returns, the controller will retain the conditions that existed prior to shut down.
- The alarm hold action is activated when only the power is turned on.

### 6.1 Operating Procedures

- Prior to starting operation, check that the mounting and wiring have been finished, and that the alarm setting value and various parameters have been set.
- A power supply switch is not furnished with this instrument. It is ready to measure as soon as the power is turned on.

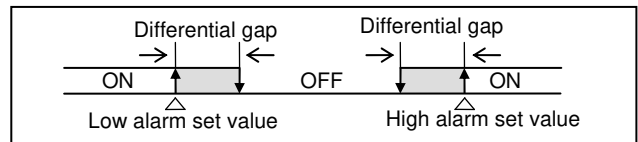

### 6.2 Set Data Lock (LCK) Function

The set data lock restricts parameter setting changes by key operation. This function prevents the operator from making errors during operation. Parameters protected by Set Data Lock function are still displayed for monitoring.

### 6.3 Alarm (ALM) Function

Each alarm action is as follows.

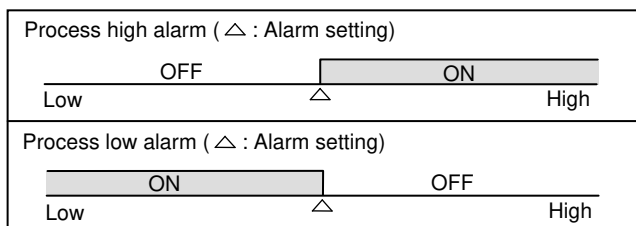

### 6.4 Alarm Differential Gap

If measured value (PV) is close to the alarm set value, the alarm relay contact may repeatedly turn ON and OFF due to input fluctuations. If the differential gap is set, repeated turning ON and OFF of the relay contact can be prevented.

### 6.5 Alarm Hold Action

In the alarm hold action, the alarm function is kept invalid even if the measured value (PV) is in the alarm range when the power is on. The alarm function is held until the measured value (PV) goes out of the alarm state once.

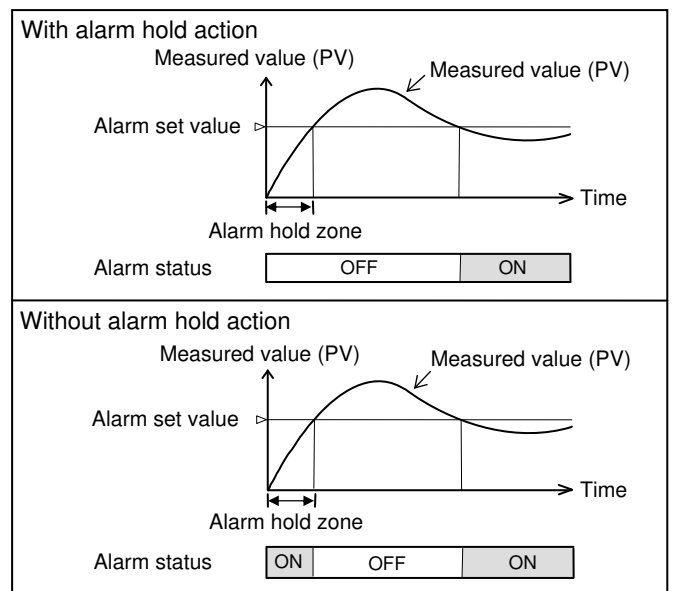

# 7. INITIAL SETTING

## ! WARNING

Parameters in the Initialization mode should be set according to the application before setting any parameter related to operation. Once the Parameters in the Initialization mode are set correctly, no further changes need to be made to parameters for the same application under normal conditions. If they are changed unnecessarily, it may result in malfunction or failure of the instrument. RKC will not bear any responsibility for malfunction or failure as a result of improper changes in the Initialization mode.

### 7.1 Go to Initialization Mode

1. Turn on the power to this controller. The instrument goes to the PV display after confirming input type symbol and input range.
2. Press and hold the set key for 2 seconds to go to the Parameter Setting Mode from the PV display.
3. Press the set key until "LCK" (Set Data Lock display) will be displayed.



Set data lock function display

4. Press the shift key to change the display from character to set value. (The    section in each image of the controller shows the digits which are not high-lighted.)



Character display of set data

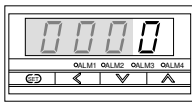

Set value display of set data

5. Press the shift key to light brightly the thousands digit.

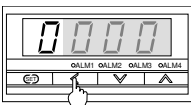

Set value display of set data

6. Press the up key to change "0" to "1" in the thousands digit.



Set value display of set data

Set value  
0: Initialization mode locked  
1: Initialization mode unlocked

7. Press the set key to change to the next parameter. Thus, the data in initialization mode is unlocked.



First alarm differential gap

The parameter displayed varies on the instrument specification.

8. Press the set key while pressing the shift key for 2 seconds. To change the instrument to initialization mode. Thus, the symbol (Cod) for selecting the initialize code is displayed first.



First alarm differential gap



Character display of initialize code selection in the initialization mode

Initialize code: Cod 0000	SL1 (Input type selection)	Refer to P. 9
	SL2 (Temperature unit selection)	Refer to P. 9
	SL3 (Alarm 1 type selection)	Refer to P. 9
	SL4 (Alarm 2 type selection)	Refer to P. 9
	SL5 (Alarm 3 type selection)	Refer to P. 9
	SL6 (Alarm 4 type selection)	Refer to P. 9
Initialize code: Cod 0001	SLH (Setting limiter [high limit])	Refer to P. 10
	SLL (Setting limiter [low limit])	Refer to P. 10
	PGdP (Setting the position of decimal point)	Refer to P. 11
	dF (Digital filter setting)	Refer to P. 11

### 7.2 Exit Initialization Mode

**When any parameter setting is changed in the Initialization Mode, check all parameter set values in Alarm Setting Mode and Parameter Setting Mode.**

1. Press the set key while pressing the shift key for 2 seconds. to transfer to PV display after each parameter is set.
2. Press and hold the set key for 2 seconds in the PV display state to transfer to parameter setting mode.
3. Press the set key to transfer to the set data lock function display (LCK).
4. Press the shift key to change the display from character to set value.
5. Press the shift key to brightly light the thousands digit.
6. Press the down key to set the numeric value corresponding to the thousands digit to "0" from "1."

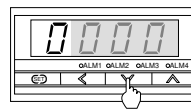

Set value display of initialize code selection in the initialization mode

Set value  
0: Initialization mode locked  
1: Initialization mode unlocked

7. Press the set key to transfer to the next parameter. As a result, the "Initialization mode lock state" setting becomes effective.



First alarm differential gap

The parameter displayed varies on the instrument specification.

### 7.3 Initial Setting Menu

The "Cod" display will be displayed when the controller goes to the Initialization Mode.

**Do not change to any parameter in the Initialization Mode which is not described in the initial setting menu above. It may result in malfunction or failure of the instrument.**

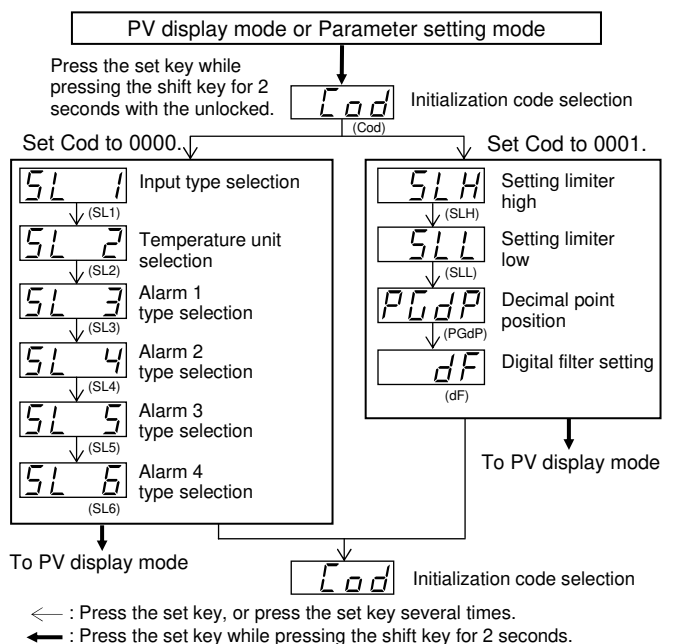

## 7.4 Input Type Selection (SL1)



When any parameter setting is changed in the Initialization Mode, check all parameter set values in Alarm Setting Mode and Parameter Setting Mode.

Factory set value varies depending on the input type.

Set value	Input type	
0000	K	Thermocouple <sup>1</sup> (TC)
0001	J	
0010	L	
0011	E	
0100	N	
0111	R	
1000	S	
1001	B	
1010	W5Re/W26Re	
1011	PL II	
0101	T	
0110	U	
1100	Pt100 Ω (JIS/IEC)	
1101	JPt100 Ω (JIS)	Voltage <sup>1</sup>
1110	0 to 5 V DC	
1110	0 to 10 V DC <sup>2</sup>	
1111	1 to 5 V DC	
1110	0 to 20 mA DC	
1111	4 to 20 mA DC	Current <sup>1,3</sup>

<sup>1</sup> Any input change in TC&RTD group is possible. Any input change in Voltage & Current group except for 0 to 10 V DC input is possible. No input change between TC&RTD group and Voltage & Current group is possible.

<sup>2</sup> The input type of Z-1010 specification is fixed to 0 to 10 V DC due to the hardware difference.

<sup>3</sup> For the current input specification, a resistor of 250 Ω must be connected between the input terminals.

### Change Settings

**Example: Change the input type from “K” to “J”**

1. Change the instrument to the initialize code selection (Cod) display.

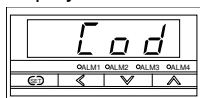

Character display of initialize code selection in the initialization mode

2. Press the shift key to change the display from character to set value.

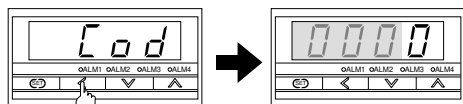

Character display of initialize code selection → Set value display of initialize code selection

3. Set “Cod” to 0000, and press the set key to change to the input type selection (SL1) display.

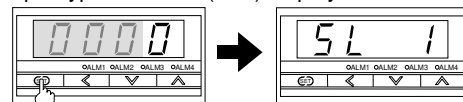

Set value display of initialize code selection → Character display of input type selection

4. Press the shift key to change the display from character to set value.

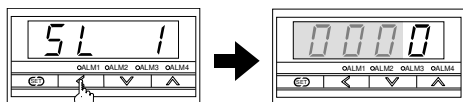

Character display of input type selection → Set value display of input type selection

5. Press the up key to change “0” to “1” in the units digit.



Set value display of input type selection

6. Press the set key to change to the next parameter. Thus, the set value is registered.

## 7.5 Temperature Unit Selection (SL2)



Inappropriate settings may result in malfunction.

Factory set value varies depending on the instrument specification.

Set value	Description
0000	°C
0001	°F

### Change Settings

**Example: Change the temperature unit from “°C (0000)” to “°F (0001)”**

1. Press the set key at the input type selection (SL1) until the temperature unit selection (SL2) is displayed.

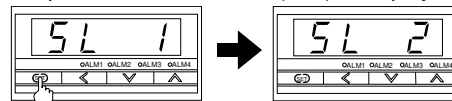

Character display of input type selection → Character display of temperature unit selection

2. Press the shift key to change the display from character to set value.

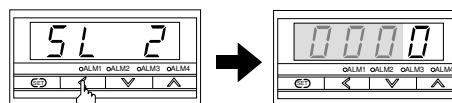

Character display of temperature unit selection → Set value display of temperature unit selection

3. Press the up key to change “0” to “1” in the units digit.



Set value display of temperature unit selection

4. Press the set key to change to the next parameter. Thus, the set value is registered.

## 7.6 Alarm 1 [ALM1] Type Selection (SL3) Alarm 2 [ALM2] Type Selection (SL4) Alarm 3 [ALM3] Type Selection (SL5) Alarm 4 [ALM4] Type Selection (SL6)



The following instrument cannot be selected.

- When the instrument does not have the alarm 1 [ALM1].
- When the instrument does not have the alarm 2 [ALM2].
- When the instrument does not have the alarm 3 [ALM3].
- When the instrument does not have the alarm 4 [ALM4].
- When the analog output specified, cannot select alarm 3.
- When the power supply for LED drive specified, cannot select alarm 4.

Factory set value varies depending on the instrument specification.

Set value	Details of setting
0000	No alarm
0001	Process high alarm (energized type)
0101	Process high alarm (de-energized type)
0011	Process low alarm (energized type)
0111	Process low alarm (de-energized type)
1001	Process high alarm with hold action (energized type) *
1101	Process high alarm with hold action (de-energized type) *
1011	Process low alarm with hold action (energized type) *
1111	Process low alarm with hold action (de-energized type) *

\* Hold action:

In the alarm hold action, the alarm function is kept invalid even if the Measured value (PV) is in the alarm range when the power is on. The alarm function is held until the Measured value (PV) goes out of the alarm state once.

Continued on the next page.

### ● Alarm action type

The first alarm, second alarm, third alarm and fourth alarm of this instrument are turned on when burnout occurs regardless of any of the following actions taken (High alarm, low alarm, etc.). In addition, when used for any purposes other than these alarms (event, etc.), specify the Z-124 specification (not to be forcibly turned on).

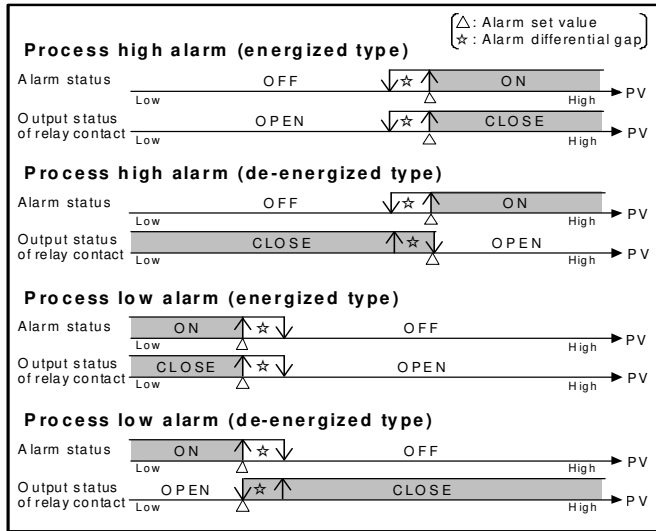

### ■ Change Settings

**Example: Change the first alarm type from “Process high alarm (energized type: 0001)” to “Process low alarm (energized type: 0011)”**

1. Press the set key several times at the input type selection (SL1) until the first alarm type selection (SL3) is displayed.

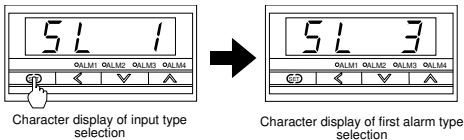

2. Press the shift key to change the display from character to set value.

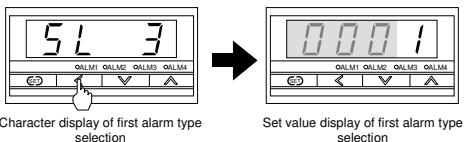

3. Press the shift key to high-light the tens digit.

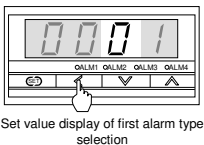

4. Press the up key to change "0" to "1" in the tens digit.

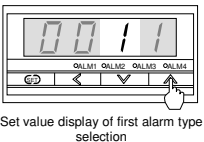

5. Press the set key to change to the next parameter. Thus, the set value is registered.

## 7.7 Setting Limiter High (SLH) Setting Limiter Low (SLL)

For voltage or current input, set scaling within the input range.

☞ Refer to 9. INPUT RANGE TABLE (P. 12)

Factory set value varies depending on the instrument specification.

Input type	Setting range		
	Setting limiter high	Setting limiter low	
TC	K	SLL to 1372 °C SLL to 2502 °F	0 to SLH °C 0 to SLH °F
	J	SLL to 1200 °C SLL to 2192 °F	0 to SLH °C 0 to SLH °F
	R	SLL to 1769 °C	0 to SLH °C
	S	SLL to 3216 °F	0 to SLH °F
	B	SLL to 1820 °C SLL to 3308 °F	0 to SLH °C 0 to SLH °F
	E	SLL to 1000 °C SLL to 1832 °F	0 to SLH °C 0 to SLH °F
	N	SLL to 1300 °C SLL to 2372 °F	0 to SLH °C 0 to SLH °F
	T	SLL to 400.0 °C SLL to 752.0 °F	-199.9 to SLH °C -199.9 to SLH °F
	W5Re/W26Re	SLL to 2320 °C SLL to 4208 °F	0 to SLH °C 0 to SLH °F
	PLII	SLL to 1390 °C SLL to 2534 °F	0 to SLH °C 0 to SLH °F
	U	SLL to 600.0 °C SLL to 999.9 °F	-199.9 to SLH °C -199.9 to SLH °F
	L	SLL to 900 °C SLL to 1652 °F	0 to SLH °C 0 to SLH °F
RTD	Pt100	SLL to 649.0 °C	-199.9 to SLH °C
	JPt100	SLL to 999.9 °F	-199.9 to SLH °F
Voltage	0 to 5 V DC	SLL to 9999 (Programmable range)	-199.9 to SLH (Programmable range)
	0 to 10 V DC *		
	1 to 5 V DC		
Current	0 to 20 mA DC		
	4 to 20 mA DC		

\* Z-1010 specification

### ■ Change Settings

**Example: When the display range is scaled to 0.0 to 400.0 for a voltage input of 1 to 5 V DC.**

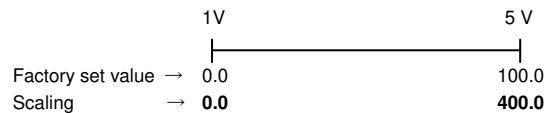

1. Change the instrument to the initialize code selection (Cod) display.

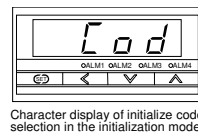

2. Press the shift key to change the display from character to set value.

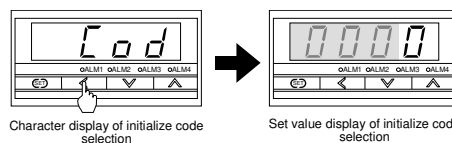

3. Press the up key to change "0" to "1" in the units digit.

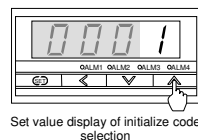

Continued from the previous page.

- Set "Cod" to 0001, and press the set key to change to the setting limiter high (SLH) display.

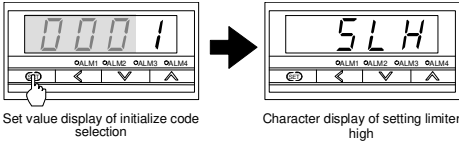

- Press the shift key to change the display from character to set value.

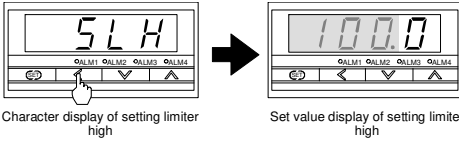

- Press the shift key several times to high-light the thousands digit.

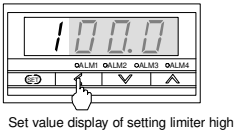

- Press the up key to change "1" to "4" in the thousands digit.

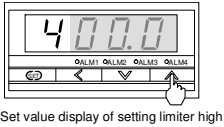

- Press the set key to change to the next parameter. Thus, the set value is registered. Check that the display is "0.0" for the setting limiter low (SLL).

## 7.8 Decimal Point Position (PGdP)

Use to select a decimal point position of the input range (voltage input and current input). PGdP is displayed only for voltage or current input.

Inappropriate settings may result in malfunction.

Set value	Description
0000	No decimal place (□□□□)
0001	One decimal place (□□□.□) [Factory set value]
0002	Two decimal places (□□.□□)
0003	Three decimal places (□.□□□)

### Change Settings

**Example: Change the decimal point position from "One decimal place (0001)" to "No decimal place (0000)"**

- Press the set key several times at the setting limiter high (SLH) until the decimal point position (PGdP) is displayed.

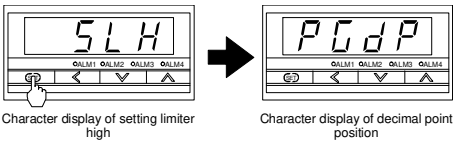

- Press the shift key to change the display from character to set value.

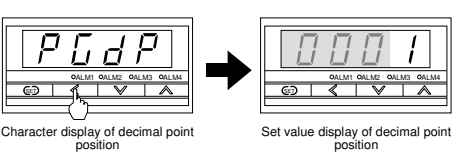

- Press the down key to change "1" to "0" in the units digit.

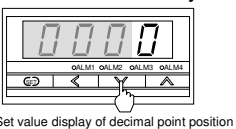

- Press the set key to change to the next parameter. Thus, the set value is registered.

## 7.9 Digital Filter Setting (dF)

This item is the time of the first-order lag to eliminate noise against the measured input.

**Setting range:** 0 to 100 seconds (0: digital filter OFF)  
**Factory set value:** 1

### Change Settings

**Example: Change the digital filter from "One seconds (0001)" to "Three seconds (0003)"**

- Press the set key several times at the setting limiter high (SLH) until the digital filter setting (dF) is displayed.

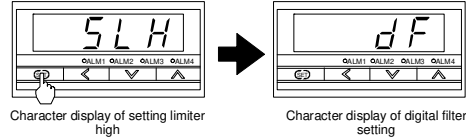

- Press the shift key to change the display from character to set value.

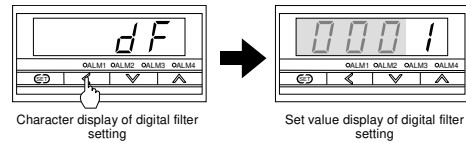

- Press the up key to change "1" to "3" in the units digit.

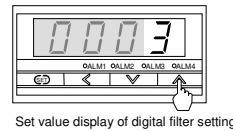

- Press the set key to change to the next parameter. Thus, the set value is registered.

## 8. ERROR DISPLAYS

### ■ Error display

<b>Err</b>	RAM failure (Incorrect set data write, etc.)	Turn off the power at once. If an error occurs after the power is turned on again, please contact RKC sales office or the agent.
------------	---	--

### ■ Over-scale and Underscale

Measured value (PV) [Flashing]	PV is outside of input range.	 <div style="border: 1px solid black; padding: 5px; display: inline-block;"><b>WARNING</b></div> <p><b>To prevent electric shock, always turn off the power before replacing the sensor.</b></p>
<b>0000</b> [Flashing]	Over-scale: PV is above the high input display range limit.	
<b>UUUU</b> [Flashing]	Underscale: PV is below the low input display range limit.	
		Check Input type, Input range and connecting state of sensor. Confirm that the sensor or wire is not broken.

## 9. INPUT RANGE TABLE

Input type	Model code	Input type	Model code	Input type	Model code	Input type	Model code	Input type	Model code
0 to 200 °C	K 01	0 to 800 °F	J A1	0 to 1200 °C	N 01	*2 -199.9 to +100.0 °C	U 02	-100.0 to +100.0 °F	D A4
0 to 400 °C	K 02	0 to 1600 °F	J A2	0 to 1300 °C	N 02	0 to 400.0 °C	U 03	-100.0 to +300.0 °F	D A5
0 to 600 °C	K 03	0 to 2192 °F	J A3	0 to 2300 °F	N A1	-199.9 to +999.9 °F	U A1	0.0 to 100.0 °F	D A6
0 to 800 °C	K 04	0 to 400 °F	J A6	0 to 23720 °F	N A2	-100.0 to +200.0 °F	U A2	0.0 to 200.0 °F	D A7
0 to 1000 °C	K 05	0 to 300 °F	J A7	*2 -199.9 to +400.0 °C	T 01	0.0 to 999.9 °F	U A3	0.0 to 400.0 °F	D A8
0 to 1200 °C	K 06	*1 0 to 1600 °C	R 01	*2 -199.9 to +100.0 °C	T 02	0 to 400 °C	L 01	0.0 to 500.0 °F	D A9
0 to 1372 °C	K 07	*1 0 to 1769 °C	R 02	-100.0 to +200.0 °C	T 03	0 to 800 °C	L 02	-199.9 to +649.0 °C	P 01
0 to 100 °C	K 13	*1 0 to 1350 °C	R 04	0.0 to 350.0 °C	T 04	0 to 800 °F	L A1	-199.9 to +200.0 °C	P 02
0 to 300 °C	K 14	*1 0 to 3200 °F	R A1	*2 -199.9 to +752.0 °F	T A1	0 to 1600 °F	L A2	-100.0 to +50.0 °C	P 03
0 to 450 °C	K 17	*1 0 to 3216 °F	R A2	-100.0 to +200.0 °F	T A2	-199.9 to +649.0 °C	D 01	-100.0 to +100.0 °C	P 04
0 to 500 °C	K 20	*1 0 to 1600 °C	S 01	-100.0 to +400.0 °F	T A3	-199.9 to +200.0 °C	D 02	-100.0 to +200.0 °C	P 05
0 to 800 °F	K A1	*1 0 to 1769 °C	S 02	0.0 to 450.0 °F	T A4	-100.0 to +50.0 °C	D 03	0.0 to 50.0 °C	P 06
0 to 1600 °F	K A2	*1 0 to 3200 °F	S A1	0.0 to 752.0 °F	T A5	-100.0 to +100.0 °C	D 04	0.0 to 100.0 °C	P 07
0 to 2502 °F	K A3	*1 0 to 32162 °F	S A2	0 to 2000 °C	W 01	-100.0 to +200.0 °C	D 05	0.0 to 200.0 °C	P 08
20 to 70 °F	K A4	*1 400 to 1800 °C	B 01	0 to 2320 °C	W 02	0.0 to 50.0 °C	D 06	0.0 to 300.0 °C	P 09
0 to 200 °C	J 01	*1 0 to 1820 °C	B 02	0 to 4000 °F	W A1	0.0 to 100.0 °C	D 07	0.0 to 500.0 °C	P 10
0 to 400 °C	J 02	800 to 3200 °F	B A1	0 to 1300 °C	A 02	0.0 to 200.0 °C	D 08	0 to 5 V	4 01
0 to 600 °C	J 03	*1 0 to 3308 °F	B A2	0 to 1390 °C	A 03	0.0 to 300.0 °C	D 09	0 to 10 V **	5 01
0 to 800 °C	J 04	0 to 800 °C	E 01	0 to 1200 °C	A 04	0.0 to 500.0 °C	D 10	1 to 5 V	to 6 01
0 to 1000 °C	J 05	0 to 1000 °C	E 02	0 to 2400 °F	A 05	-199.9 to +999.9 °F	D A1	0 to 20 mA	100.0 7 01
0 to 1200 °C	J 06	0 to 1600 °F	E A1	0 to 2534 °F	A 06	-199.9 to +400.0 °F	D A2	4 to 20 mA	8 01
0 to 450 °C	J 10	0 to 1832 °C	E A2	U *2 0 to 450 °C	U 01	-199.9 to +200.0 °F	D A3		

\*1 0 to 399 °C/0 to 799 °F: Accuracy is not guaranteed.

\*2 -199.9 to -100.0 °C/-199.9 to -158.0 °F: Accuracy is not guaranteed.

\*\* Z-1010 specification

## 10. REMOVING THE INTERNAL ASSEMBLY

Usually, this instrument is not necessary to remove the internal assembly from the case. When removing the internal assembly without disconnecting the external wiring, take the following steps.

### ⚠ **WARNING**

- To prevent electric shock or instrument failure, only qualified personnel should be allowed to pull out the internal assembly.
- To prevent electric shock or instrument failure, always turn off the power before pulling out the internal assembly.
- To prevent injury or instrument failure, do not touch the internal printed wiring board.

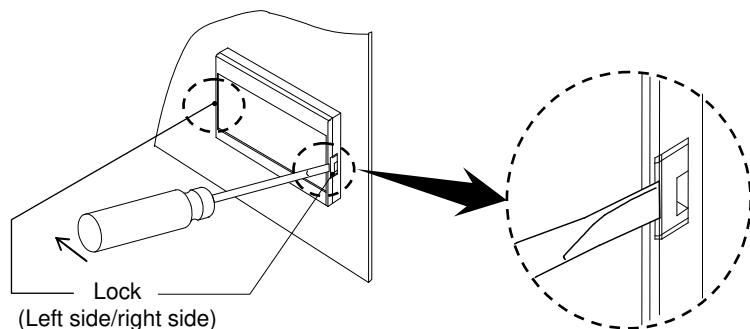

Unlock using such a screwdriver.  
Gently press outside on handle.

Recommended tool: Slotted screwdriver  
(Tip width: 6 mm or less)

 Apply pressure very carefully when removing internal assembly to avoid damage to the frame.

 To conform to IEC61010-1 requirements for protection from electric shock, the internal assembly of this instrument can only be removed with an appropriate tool.

The first edition: AUG. 1999  
The eighth edition: MAY 2013 [IMQ00]